

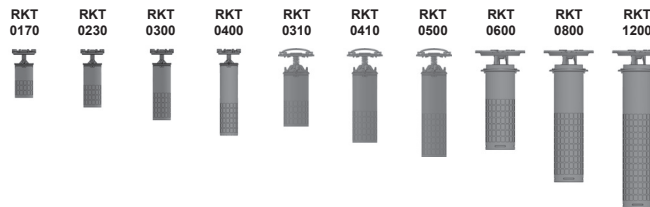

RT FILTER TECHNIK

Spare Parts List Return Line Filter RKT

Flow direction from in to out
up to 1,200 l/min, up to 10 bar



1. MAINTENANCE

1.1 GENERAL

Please follow the maintenance instructions!

1.2 INSTALLATION

In the top part of the reservoir, there is an inlet chamber which holds the tank flange and the housing tube. The filter element is plugged into housing pipe in the hydraulic tank. This is accessed via the tank opening.

Before fitting the filter into the system, check that the operating pressure of the system does not exceed the permitted operating pressure of the filter. Please observe the removal height of the filter element. Refer to the type code label on the filter!

1.3 COMMISSIONING

Check that the correct filter element is fitted. Place the cover and tighten cover bolts alternately. Switch on hydraulic system and vent filter at a suitable point in the system. Check the filter for leakage.

1.4 TOOLS REQUIRED FOR MAINTENANCE

RKT	Cover Nut/ Screws	Int. hex. Allen Key	Torque Value In Steel
0170, 0230, 0300, 0400	M10	AF width 16	25 Nm
0310, 0410, 0500	M12	AF width 18	30 Nm
0600, 0800, 1200	M12	AF width 18	30 Nm

2. CHANGING THE ELEMENT

2.1 REMOVING THE ELEMENT

1. Switch off hydraulic system and release filter pressure (if necessary, release the pressure in the tank).
2. Loosen the cover screws and remove the cover in a vertical upward movement.
3. For series 0170 – 0400:
Pull element from the valve seat with the clamp. Let the residual oil drip into the filter housing. Remove the clamp from the element with an anti-clockwise rotary movement.
For the series 0310 – 0500:
Remove clamp from bayonet lock with a clockwise rotary movement and pull vertically from the housing tube. Pull element out of the housing tube. Let the residual oil drip into the filter housing.
For series 0600 – 1200:
Here, the clamp is connected to the cover. After removing the cover, lift the filter element from the filter housing and let the residual oil drip into the filter housing.
4. Examine element surface and magnetic core for dirt residues and larger particles since these can be an indication of damage to components.
5. Replace or clean filter element (only WPI elements can be cleaned).
6. Clean housing and magnetic core.
7. Examine filter, especially sealing surfaces, for mechanical damage.
8. Check O-rings – and replace if necessary.

2.2 FITTING THE ELEMENT

1. Lubricate the sealing surfaces on the filter housing and cover, as well as the O-ring, with clean operating fluid.
2. When fitting a new filter element, check that the designation corresponds to that of the old element.
For series 0170 – 0400:
Snap the clamp with spring into place at the element with a clockwise rotary movement. Insert the filter element into the filter housing and press into the O-ring flap.
For series 0310 – 0500:
Insert filter element into the housing tube. With a rotating movement, make sure that the element and spring-nut connection is in place and fully in contact with the base. Fit clamp with spring and lock bayonet in anti-clockwise direction.
For series 0600 – 1200:
Insert the filter element into the filter housing and press into the O-ring flap.
3. Fit cover with magnetic core.
For series 0600 - 1200: Fit covers with a rotary movement, so that the polygon shape of the clamp is in the counter piece of the element. Then, align the screw drill holes on the cover to the threaded holes in the flange. Tighten cover screws/ nuts by hand. Then tighten alternately and observe the torques specified by the machine manufacturer.
4. If necessary, refill hydraulic oil.
5. Switch on hydraulic system and vent filter at a suitable point in the system.
6. Check the filter for leakage.

NOTICE:

Filter elements which cannot be cleaned must be disposed of in accordance with environmental protection regulations!

3. SPARE PARTS

3.1 SPARE PARTS DRAWING RKT 0170, 0230, 0300, 0400

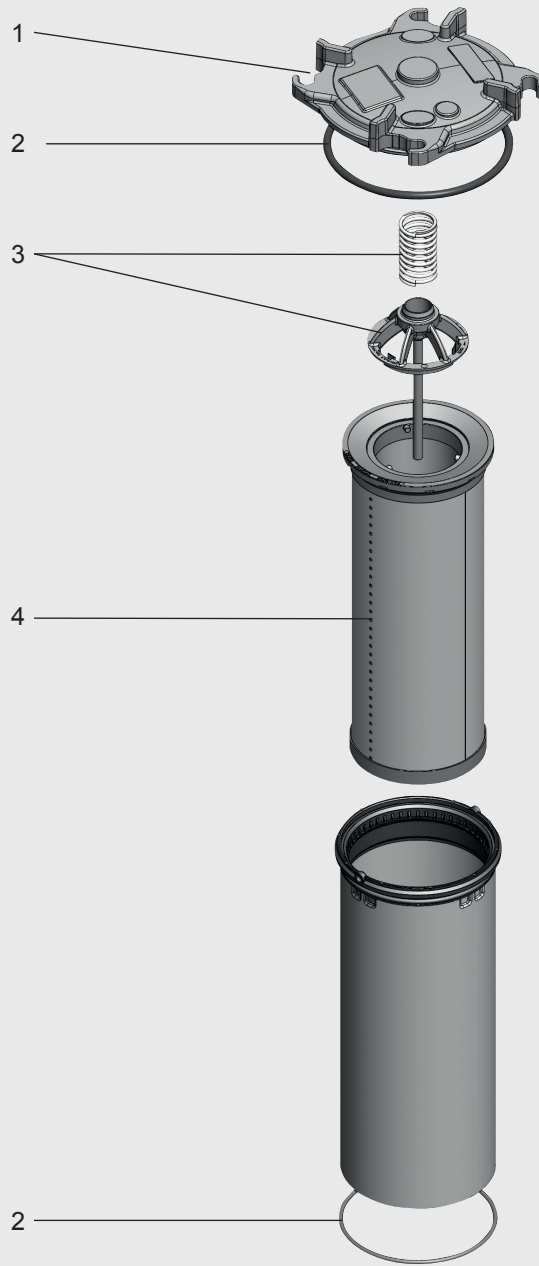

3.2 Spare Parts List RKT 0170, 0230, 0300, 0400 (specified in NBR seals)

Item	RKT 0170	RKT 0230	RKT 0300	RKT 0400
1.	RKT cover kpl 0170 – 0400 (Material no: 200132)			
2.	RKT seal kit kpl 0170 – 0400 (Material no: 200133) Cover: O-ring ISO3601-1-142x7-N-NBR-Sh70			
3.	RKT clamp with magnetic core kpl 0170 – 0400 (Material no.: 200134) RKT clamp without magnetic core kpl 0170 – 0400 (Material no.: 200135)			
4.	Filter element ULP-00xx-117-X509-S-N-RT UMC-00xx-117-X509-S-N-RT WPI-00xx-117-X509-S-N-RT	Filter element ULP-00xx-117-X512-S-N-RT UMC-00xx-117-X512-S-N-RT WPI-00xx-117-X512-S-N-RT	Filter element ULP-00xx-117-X516-S-N-RT UMC-00xx-117-X516-S-N-RT WPI-00xx-117-X516-S-N-RT	Filter element ULP-00xx-117-X520-S-N-RT UMC-00xx-117-X520-S-N-RT WPI-00xx-117-X520-S-N-RT
xx = filtration rating				

For special model FKM seal, please contact our sales!

3.3 SPARE PARTS DRAWING RKT 0310, 0410, 0500

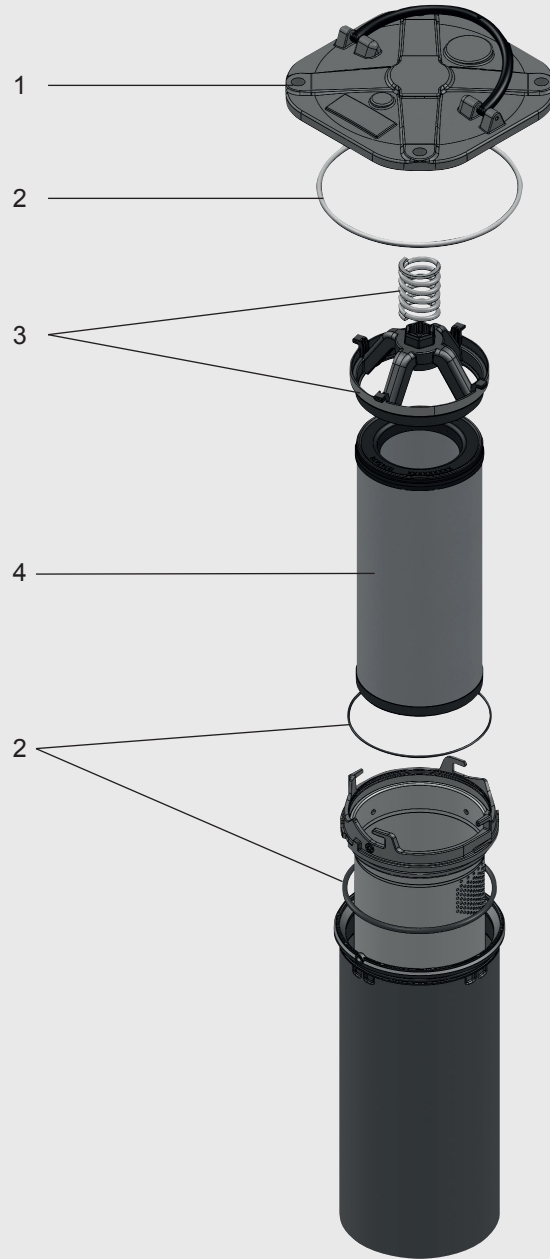

3.4 Spare Parts List RKT 0310, 0410, 0500 (specified in NBR seals)

Item	RKT 0310	RKT 0410	RKT 0500
1.	RKT cover kpl 0310 – 0500 (Material no: 200136)		
2.	RKT seal kit kpl 0310 – 0500 (Material no: 200107) Cover: O-ring ISO3601-1-183.52x5.33-NBR-Sh70 Clamp: O-ring ISO 3601-1-133x2.62-NBR-Sh70 Housing pipe: O-ring ISO 3601-1-145.64x3.53-NBR-Sh70		
3.	RKT clamp with magnetic core kpl 0310 – 0500 (Material no.: 200137) RKT clamp without magnetic core kpl 0310 – 0500 (Material no.: 200138)		
4.	Filter element ULP-00xx-120-XZ11-Q-P-RT UMC-00xx-120-XZ11-Q-P-RT WPI-00xx-120-XZ11-Q-P-RT	Filter element ULP-00xx-120-XZ14-Q-P-RT UMC-00xx-120-XZ14-Q-P-RT WPI-00xx-120-XZ14-Q-P-RT	Filter element ULP-00xx-120-XZ18-Q-P-RT UMC-00xx-120-XZ18-Q-P-RT WPI-00xx-120-XZ18-Q-P-RT
xx = filtration rating			

For special model FKM seal, please contact our sales!

3.5 SPARE PARTS DRAWING RKT 0600, 0800, 1200

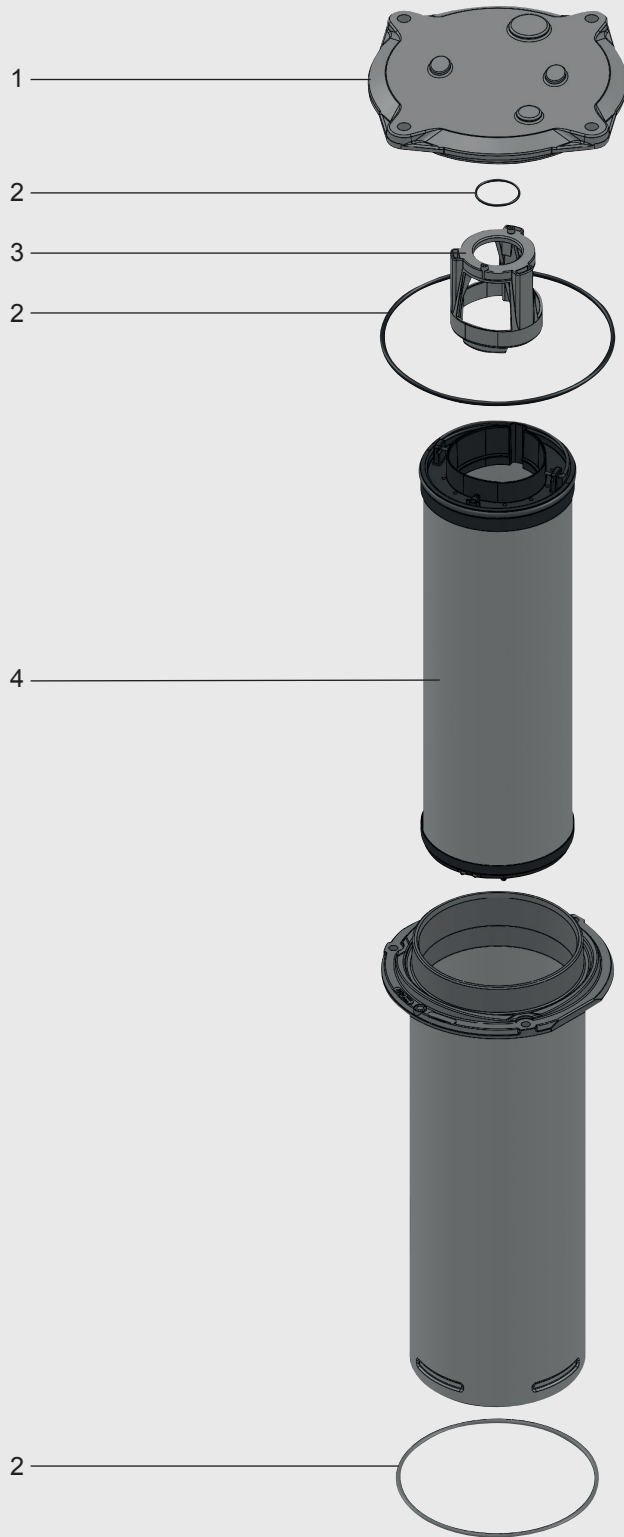

3.6 Spare Parts List RKT 0600, 0800, 1200
(specified in NBR seals)

Item	RKT 0600	RKT 0800	RKT 1200
1.	RKT cover with magnetic core kpl 0600 – 1200 (Material no.: 200139) RKT cover without magnetic core kpl 0600 – 1200 (Material no.: 200140)		
2.	RKT seal kit kpl 0600 – 1200 (Material no: 200141) Cover: O-ring-ISO3601-1-372A-221.62x5.33-N-NB-70Sh Clamp: O-ring 40.0x3.0-NBR-70Sh Cover: O-ring-ISO3601-1-367A-189.87x5.33-N-NBR-70Sh		
3.	RFT clamp kpl 0600 – 1200 (Mat.no.: 200150)		
4.	Filter element ULP-00xx-152-X218-S-N-RT UMC-00xx-152-X218-S-N-RT WPI-00xx-152-X218-S-N-RT	Filter element ULP-00xx-152-X225-S-N-RT UMC-00xx-152-X225-S-N-RT WPI-00xx-152-X225-S-N-RT	Filter element ULP-00xx-152-X231-S-N-RT UMC-00xx-152-X231-S-N-RT WPI-00xx-152-X231-S-N-RT
xx = filtration rating			

For special model FKM seal, please contact our sales!

4. MAINTENANCE INSTRUCTIONS

4.1 USER INSTRUCTIONS FOR FILTERS



Notice

This pressure equipment must only be put into operation in conjunction with a machine or system.



Notice

The pressure equipment must only be used as stipulated in the operating instructions of the machine or system.



Notice

This pressure equipment must only be operated using hydraulic or lubricating fluid.



Caution

The user must take appropriate action (e.g. air venting) to prevent the formation of air pockets.



Caution

Repair, maintenance work and commissioning must be carried out by specialist personnel only.

Allow the pressure equipment to cool before handling.

The stipulations of the operating instructions of the machine or system must be followed.



Danger

Caution: pressure equipment! Before any work is carried out on the pressure equipment, ensure the pressure chamber concerned (filter housing) is depressurised.



Danger

On no account may any modifications (welding, drilling, opening by force, etc.) be carried out on the pressure equipment.



Notice

It is the responsibility of the operator to comply with the water regulations of the country concerned.



Caution

Statutory accident prevention regulations, safety regulations and safety data sheets for fluids must be observed.



Caution

Filter housing must be earthed.



Caution

When working on, or in the vicinity of, hydraulic systems, naked flames, spark generation and smoking are forbidden.



Caution

Hydraulic oils and water-polluting fluids must not be allowed to enter the soil or watercourses or sewer systems.

Please ensure safe and environmentally friendly disposal of hydraulic oils. The relevant regulations in the country concerned with regard to ground water pollution, used oil and waste must be complied with.



Caution

Whenever work is carried out on the filter, be prepared for hot oil to escape which can cause injury or scalding as a result of its high pressure or temperature.



Danger

When using electrical clogging indicators, the electrical power supply to the system must be switched off before removing the clogging indicator connector.



Caution

Filters with switching valve are designed to have a permissible leakage depending on the operating medium. This is independent of the operating medium.

Customer Information in respect of Machinery Directive 2006/42/EC

Hydraulic filters are fluid power parts/ components and are therefore excluded from the scope of the Machinery Directive. They will not bear the CE mark! Before using these components, ensure compliance with the specifications provided by RT Filtertechnik GmbH in this documentation.

The specifications also contain information on the relevant essential health and safety requirements (based on Machinery Directive 2006/42/EC) that are to be applied by the user.

We hereby declare that the filters are intended to be incorporated into machinery within the terms of the Machinery Directive 2006/42/EC.

It is prohibited to put the filters into service until the machinery as a whole is in conformity with the provisions of the Machinery Directive.

Furthermore, our Terms of Sale and Delivery are available on our website (www.rt-filter.de).

SERVICE ADDRESSES

RT-Filtertechnik GmbH
Buchholz 4
D-88048 Friedrichshafen
Postfach 2160
D-88011 Friedrichshafen
Tel.: +49 7541 508-0
Fax: +49 7541 508-101
E-mail: sales@rt-filter.de

6.2 MAINTENANCE, GENERAL

This section describes maintenance work which must be carried out periodically. The operational safety and life expectancy of the filter, and whether it is ready for use, depend to a large extent on regular and careful maintenance.

6.3 MAINTENANCE MEASURES

- Spare parts must fulfil the technical requirements specified by the manufacturer. This is always ensured when using original RT spare parts.
- Keep tools, working area and equipment clean.
- After disassembling the filter, clean all parts, check for damage or wear and replace parts if necessary.
- When changing a filter element, a high level of cleanliness must be observed!

6.4 INTERVAL BETWEEN ELEMENT CHANGES

We generally recommend changing the filter elements at the latest after an operating time of 1 year. When no clogging indicator has been fitted, we recommend changing the elements at specific intervals (the frequency of changing the filter elements depends on the filter design and the conditions under which the filter is operated). When filter elements are subject to high dynamic loading it may prove necessary to change them more frequently. The same applies when the hydraulic system is commissioned or repaired or when the oil is changed. Standard clogging indicators only take effect when the filter is subject to flow. With electrical indicators the signal can also be converted into a continuous display on the control panel. In this case the continuous display must be switched off during a cold start or after changing the element. If the clogging indicator responds during a cold start only, it is possible that the element does not yet need to be changed.

NOTICE

The information in this brochure relates to the operating conditions and applications described. For applications or operating conditions not described, please contact the relevant technical department. All technical details are subject to change.