

RT Return Line Filter

The Standard Product Range
for Optimized Air Separation



Optimized air separation

An optimum air separation in a hydraulic system can only be achieved by a combination of an optimized filter and tank. Our new standard product range for optimized air separation offers the best way to protect the system from air and the resulting consequences. Hereafter, the special features of our filters are listed and it is also shown how the air separation ability of a filter-tank system can be significantly improved.

Flow direction

All filters of the series are flown from the inside to the outside. This flow direction ensures the enclosure of the contamination on the dirt side during element change and it provides the option of installing magnetic cores. The most important property however is the flow slowdown towards the tank. Due to the larger opening profile the oil flows out of the filter more slowly. There is more time available for the air bubbles to rise. The smooth and slow oil flow also ensures a calm oil surface in the tank. Thus, a renewed penetration of air into the fluid by splattering in the tank is prevented.

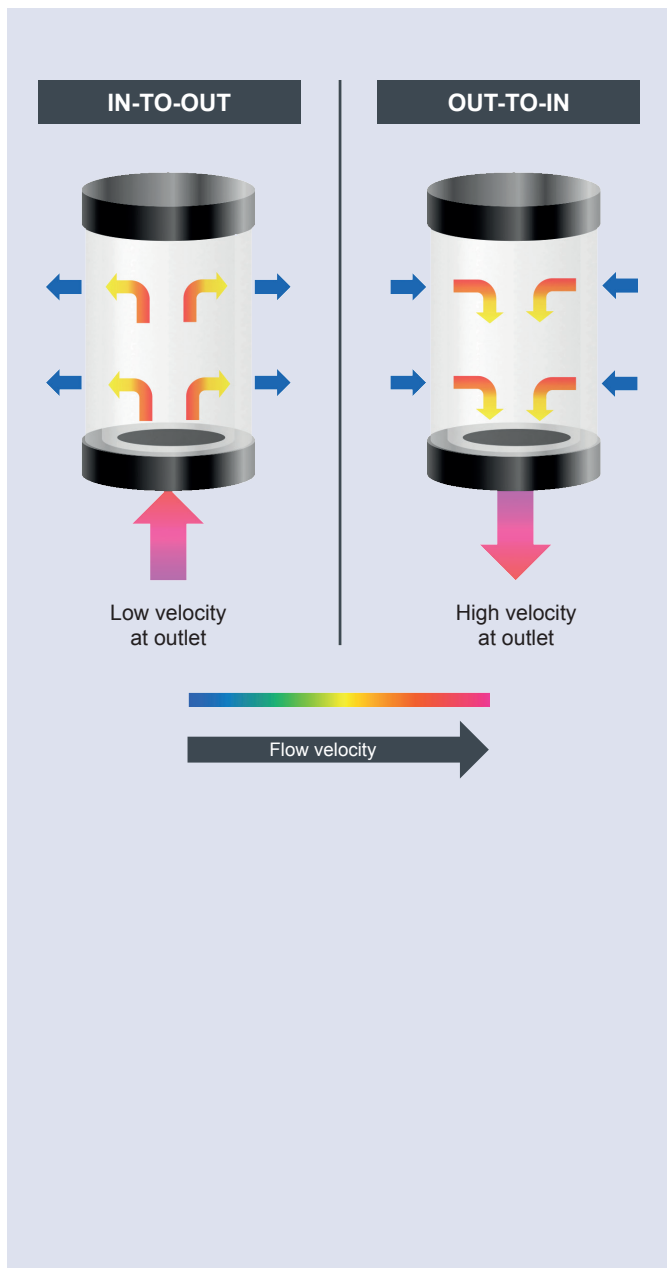

Coalescence

The rising time of an air bubble in the oil depends on the bubble diameter in a squared dependency. A ten times smaller bubble has a 100 times longer rising time. The smaller the bubbles are, the higher the risk of carrying them away.

Due to the fine filter material the bubbles are crushed by flowing of the oil through the filter media. The rising time of the bubbles increases and hence the air separation capacity of the system decreases significantly. The innovative hydraulic filters with the patented "window solution" enables a fusing of small bubbles into bigger ones at the wire mesh. This fusing is called coalescence. These larger bubbles rise much faster and the air separation is extensively improved.

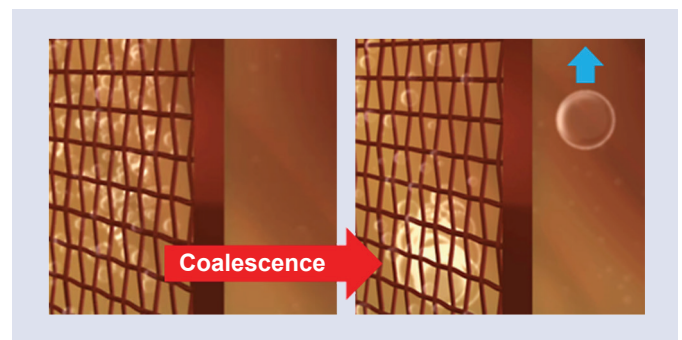

Coalescence at wire mesh

Inlet geometry

If the filter tank system allows a flow from below, a part of the oil can flow out through the windows above or near the oil surface into the tank. Therefore the rising distance for air bubbles towards the surface is reduced to a minimum. The air separation of the system is increased again.

	OUT-TO-IN Standard		OUT-TO-IN with diffuser		IN-TO-OUT optimized	
	Bubble size	Flow velocity	Bubble size	Flow velocity	Bubble size	Flow velocity
Upstream	Medium ↓ Crushing	Medium	Medium ↓ Crushing	Medium	Medium ↓ Crushing	Medium
Filter medium	Small ↓ Crushing	Low	Small ↓ Crushing	Low	Small ↓ Crushing	Low
2. Stage	None		Diffusor		Window solution	
Downstream	Small	High	Small	High	Large ↓ Coalescence	Very low

Conclusion	Small bubbles with high velocity	Small bubbles with high velocity	Large bubbles with very low velocity
Air separation	Not optimized	Improved	Very good
Oil slowdown	None	Low	Optimum

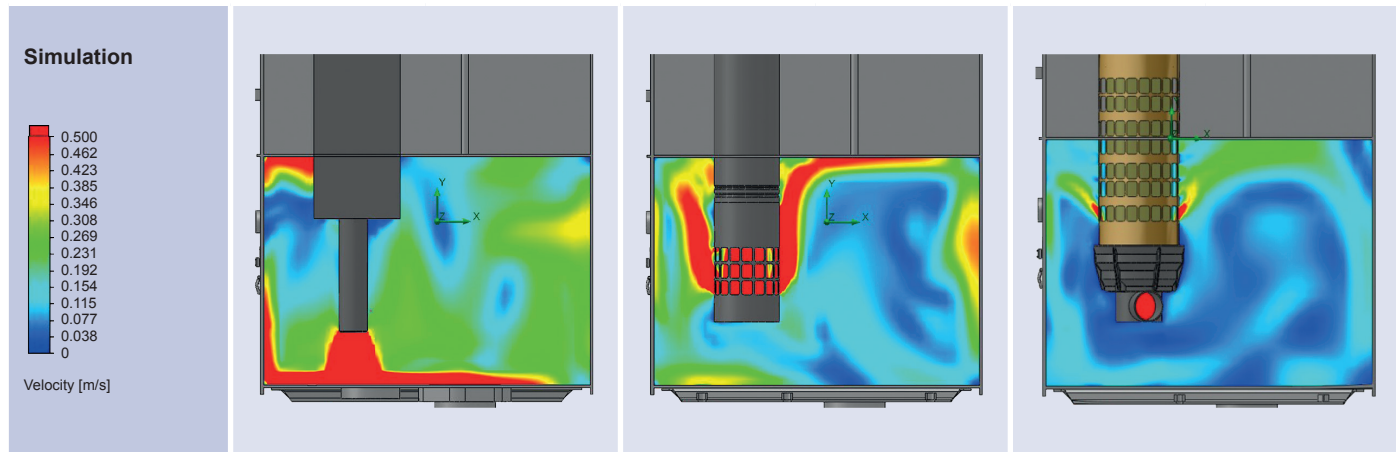

The Products

RKT: Return Line Kit – Top

- In-tank integrated
- Flow from the top
- High connection variability
- Option: with cover
- Option: with magnetic core
- Option: with Quality Protection

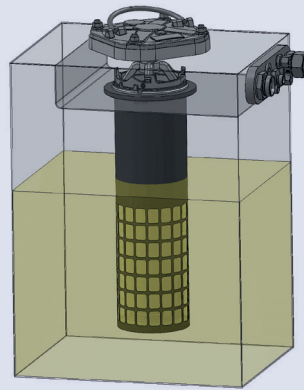

RKB: Return Line Kit – Bottom

- In-tank integrated
- Flow from bottom
- Bypass valve integrated in the element
- High connection variability
- Option: with anti-drain valve
- Option: with Quality Protection

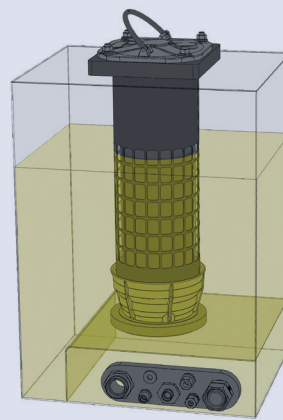

RFT: Return Line Filter – Top

- Complete filter solution
- Flow from the top
- Filter head version
- Bypass valve integrated in the element
- Option: with magnetic core
- Option: with Quality Protection

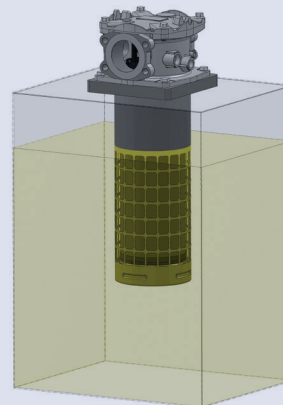

RFB: Return Line Filter – Bottom

- Complete filter solution
- Flow from bottom or side respectively
- Bypass valve on cover and element (split)
- Option: with anti-drain valve
- Option: with Quality Protection

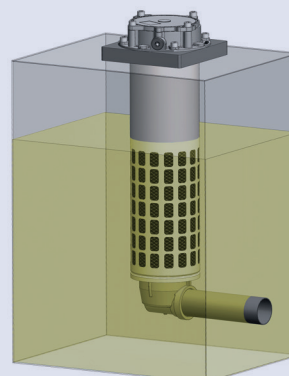

The Variants

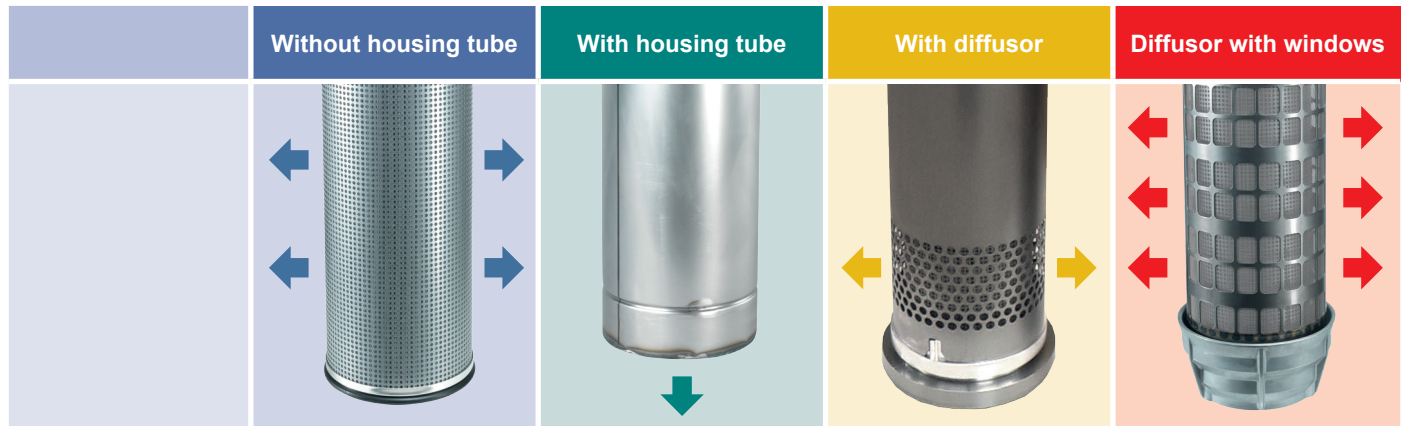

Features

- Economy version

- Guidance of return flow under oil level

- Lateral outflow into the tank
- Improved tank mixing

- Active air separation by outflow geometry and wire mesh
- Smooth flow into the tank
- Possibility for tank optimization

Air separation (Example: RFT)

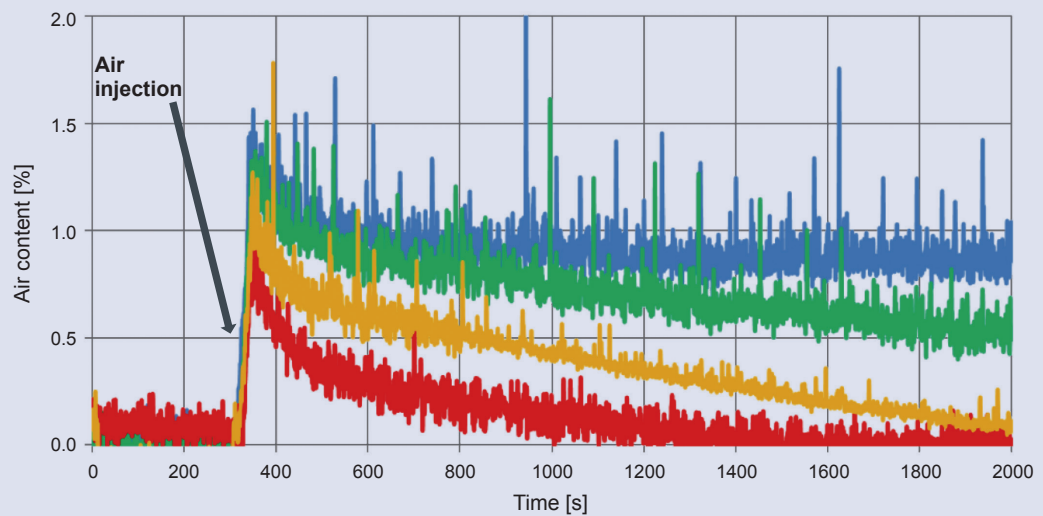

Legend:

- without tube
- with tube
- with diffusor
- diffusor with windows

- **After air injection:** constant air content of approx. 0.9 %
- Initial level is **never achieved**

- **After air injection:** roughly decreasing air content
- **After 2000 s:** initial level is not achieved

- **After air injection:** decreasing air content
- **After 2000 s:** almost at initial level

- **After air injection:** decreasing air content
- **After 1200 s:** at initial level

Availability

Filter type	Without housing tube	With housing tube	With diffusor	Diffusor with windows
RKT	●	●	●	●
RKB			●	●
RFT	●	●	●	●
RFB			●	●

RKT Return Line Kit – Top

Description







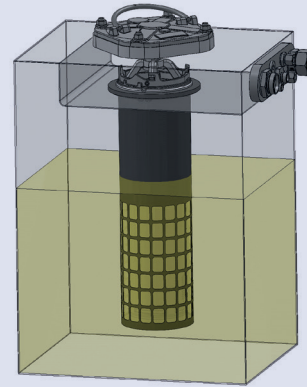

This filter system provides an economic solution of full-flow return line filtration with large flow rates. The filter is mounted in the intermediate chamber that is formed in the upper part of the tank. That means it is fully integrated into the tank allowing any return line connection design. Moreover, several filters can easily be used without the problem of splitting up the return lines.

The optional magnetic core is connected to the filter element by a bayonet fitting and guarantees an effective magnetic pre-filtration. The magnetic core is integrated into the clamp for series RKT 0170 – 0500, and integrated into the cover for series RKT 0600 – 1200.

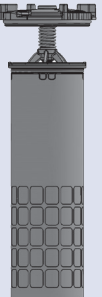
Mounting position

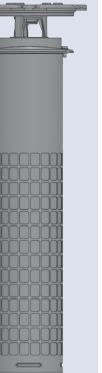

Product range

0170	0230	0300	0400	0310	0410	0500	0600	0800	1200
									
Element: Ø 117 mm				Element: Ø 120 mm			Element: Ø 152 mm		

Benefits & Properties

- Compact, tank integrated design
- RKT 0310 – 0500 with fully combustible element including Quality Protection
- Cost optimized solution, offering high flexibility in terms of connection configuration
- Service-friendly filter design
- Option: with magnetic core
- Quality Protection available for all filter types

Technical Data

- Nominal pressure: 10 bar
- Temperature range: -30°C to +100°C
- Bypass cracking pressure: 2.5 bar
- Collapse pressure element: 6 bar
- Material of cover: EN-AC-46100
- Material of housing tube: Steel
- Seals: Perbunan NBR

Note:
Please refer to the equivalent data sheets for further performance data.

RKB Return Line Kit – Bottom

Description

The RKB filters are suitable for medium to high flow rates. The filter is mounted in the intermediate chamber that is formed in the bottom part of the tank. Contaminated oil flows into the filter from below and filtered oil flows into the tank via a riser tube. The filter is fully integrated into the tank allowing any return line connection design. Moreover, several filters can easily be used without the problem of splitting up the return lines.

Optimal flow conditions in the chamber guarantee an optimum of air separation and an extended filter service life. In addition, the patented anti-drain valve can be used for improved serviceability.

Mounting position

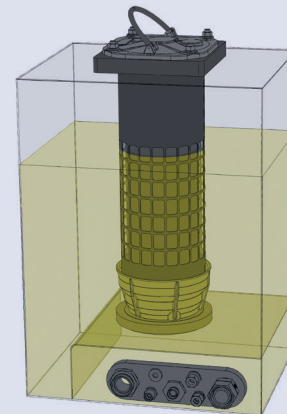

Product range

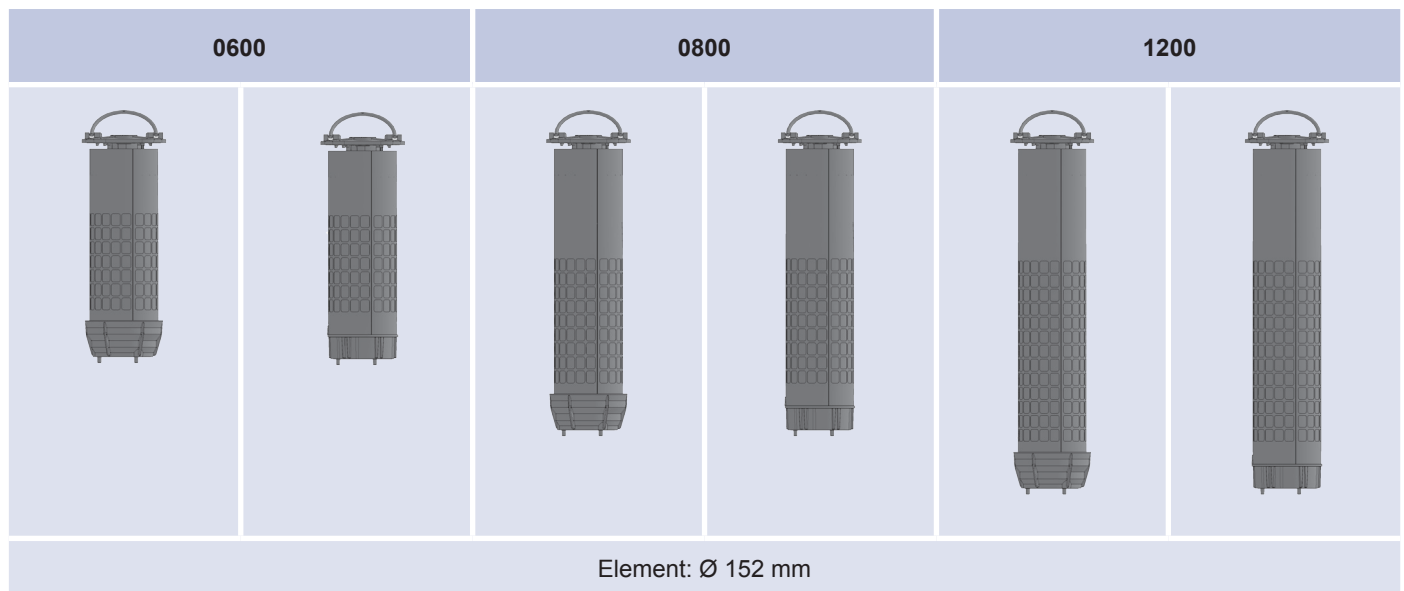

Benefits & Properties

- Compact, tank integrated return line concept
- Flow into the filter from the bottom
- Cost optimized solution, offering high flexibility in terms of connection configuration
- Service-friendly filter design
- Option: with anti-drain valve
- Quality Protection available for all filter types

Technical Data

- Nominal pressure: 10 bar
- Temperature range: -30° C to +100° C
- Bypass cracking pressure: 2.5 bar
- Collapse pressure element: 6 bar
- Material of cover: EN-AC-46100
- Material of housing tube: Steel
- Seals: Perbunan NBR

Note:

Please refer to the equivalent data sheets for further performance data.

RFT Return Line Filter – Top

Description

This filter system for medium to high flow rates is mounted on the tank. The filter head offers various connecting options from G ¾" to G 2" or SAE 1 ¼" to SAE 2".

The optional magnetic core is connected to the filter element by a bayonet fitting and guarantees an effective magnetic pre-filtration. The magnetic core is integrated into the clamp for series RFT 0170 – 0500, and integrated into the cover for series RFT 0600 – 1200.

A special feature of this product family is the optional element design with no support tube for series RFT 0310, 0410 and 0500.

Mounting position

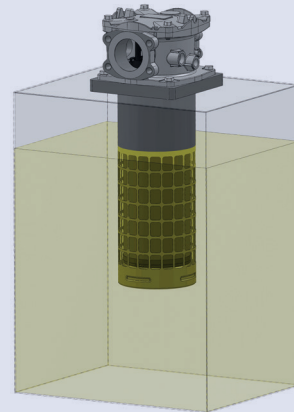

Product range

0170	0230	0300	0400	0310	0410	0500	0600	0800	1200
Element: Ø 117 mm				Element: Ø 120 mm			Element: Ø 152 mm		

Benefits & Properties

- Compact, tank top filter design
- Elements modular / identical to RKT solution
- RFT 0310 – 0500 with fully combustible element including Quality Protection
- Service-friendly filter design
- Option: with magnetic core
- Quality Protection available for all filter types
- Various connection configurations available

Technical Data

- Nominal pressure: 10 bar
- Temperature range: -30°C to +100°C
- Bypass cracking pressure: 2.5 bar
- Collapse pressure element: 6 bar
- Material of cover/head: EN-AC-46100
- Material of housing tube: Steel
- Seals: Perbunan NBR

Note:

Please refer to the equivalent data sheets for further performance data.

RFB Return Line Filter – Bottom

Description

The RFB filters are suitable for medium to high flow rates. These filters are mounted in the tank and featured with lateral or bottom flow. The optimal flow conditions from below guarantee best air separation, high pulsation stability and an extended filter service life.

In addition the innovative filters offer a variety of other features such as the anti-drain valve or the use of an intelligent clogging indicator.

Mounting position

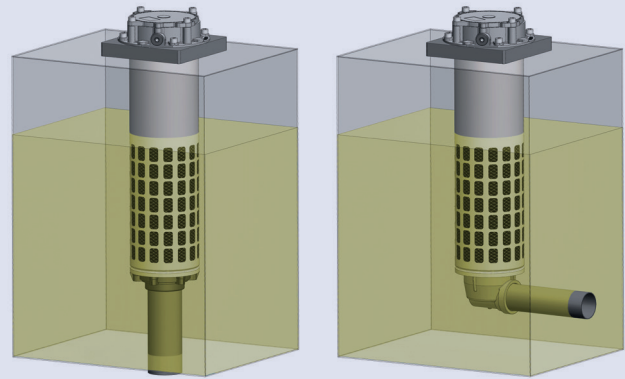

Product range

0170		0300		0400		600	
Element: Ø 108 mm				Element: Ø 120 mm			

Benefits & Properties

- Compact, tank integrated return line concept
- Flow into the filter from the bottom or the side
- Cost optimized solution
- Service-friendly filter design
- Option: with intelligent clogging indicator
- Option: with anti-drain valve
- Quality Protection available for all filter types

Technical Data

- Nominal pressure: 10 bar
- Temperature range: -30° C to +100° C
- Bypass cracking pressure: 2.5 bar
- Collapse pressure element: 6 bar
- Material of cover: EN-AC-46100
- Material of housing tube: Steel
- Seals: Perbunan NBR

Note:

Please refer to the equivalent data sheets for further performance data.

RFB Return Line Filter – Bottom

Special Features

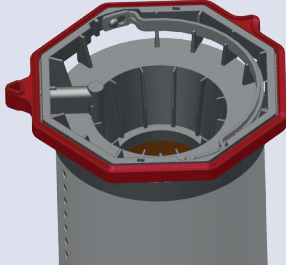
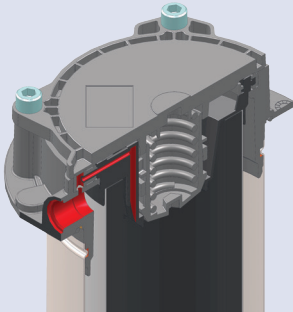
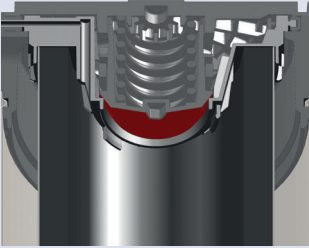
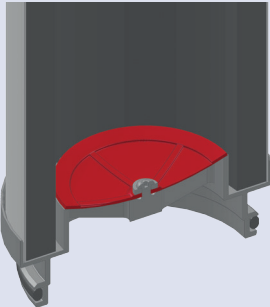
Features	Properties	Customer Benefit
<p>Cap with integrated sealing</p> 	<ul style="list-style-type: none"> ● Housing sealing located on the element ● Sealing is replaced with each element change ● Patented ● Mechanical Quality Protection 	<ul style="list-style-type: none"> ● Securing the spare element business ● Increased reliability of the machine, thanks to the use of original elements
<p>Flow duct to differential pressure measurement</p> 	<ul style="list-style-type: none"> ● A borehole channel within the element cap connects the dirt side with the indicator, in order to measure differential pressure ● Intelligent clogging indicator can be used (analogue differential pressure measuring, remaining service life determination, No-Element-Function ...) ● Electronical Quality Protection 	<ul style="list-style-type: none"> ● Securing the spare element business ● Increased reliability of the machine, thanks to the use of original elements ● Filter change can be scheduled ● Filter Condition Monitoring (Bypass monitoring, pump pressure monitoring ...)
<p>Integrated bypass valve</p> 	<ul style="list-style-type: none"> ● Split bypass valve (spring in the housing, valve seat in the element) ● Patented ● Mechanical Quality Protection 	<ul style="list-style-type: none"> ● Securing the spare element business ● Increased reliability of the machine, thanks to the use of original elements
<p>Anti-drain valve</p> 	<ul style="list-style-type: none"> ● Prevents the oil from returning from dirt side to clean side during element change ● Dirt is caught in the element ● Patented 	<ul style="list-style-type: none"> ● Improved serviceability ● Reduced oil leakage during element change



**RT-Filtertechnik
GmbH**

Postfach 21 60
D-88011 Friedrichshafen
Tel.: +49 7541 508-0
Fax: +49 7541 508-101
e-Mail: sales@rt-filter.de
Internet: www.rt-filter.de