

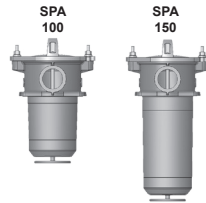

## Spare Parts List Suction Filter SPA 100, 150 Element flow direction from in to out up to 150 l/min



### 1. MAINTENANCE

#### 1.1 GENERAL

Please follow the maintenance instructions!

#### 1.2 INSTALLATION

An installation flange is provided in the tank for the suction filter. It must be designed so that the foot valve in the tank remains under the oil level in all operation conditions. The filter can be installed horizontally or vertically. The suction line is located in the housing of the filter head. Please observe the removal height of the filter element. Before fitting the filter into the system, check that the operating pressure of the system does not exceed the permitted operating pressure of the filter. Refer to the type code label on the filter!

#### 1.3 COMMISSIONING

Check that the correct filter element is fitted. Fit cover and screw in cover bolts alternately. Switch on hydraulic system and vent filter at a suitable point in the system. Check the filter for leakage.

#### 1.4 TOOLS REQUIRED FOR MAINTENANCE

SPA	Tightening torque	External hexagon spanner (cover)
100, 150	20 Nm	SW13

#### 1.5 TIGHTENING TORQUES FOR CLOGGING INDICATORS

Type	Max. torque
100, 150	15 Nm

### 2. CHANGING THE ELEMENT

#### 2.1 REMOVING THE ELEMENT

1. Switch off hydraulic system and release filter pressure (if necessary, release the pressure in the tank).
2. Loosen the hexagon nuts on the cover until they are flush with the stud screws. Unlock the cover by turning it slightly and pull out the hexagon nuts as far as the stop (foot valve is closed at the same time as a result).
3. Loosen oil drain plug (if available) and collect fluid in a suitable container, and clean or dispose of it in accordance with environmental regulations.
4. Unscrew filter cover from the locking mechanism and remove by pulling the cover (bayonet lock).
5. Unscrew filter element from the filter cover (examine element surface for dirt residues and larger particles since these can be an indication of damage to components).
6. Replace or clean filter element (only WPI elements can be cleaned).
7. Clean housing, cover and magnetic core.
8. Examine filter, especially sealing surfaces, for mechanical damage.
9. Check O-rings – and replace if necessary.

#### 2.2 FITTING THE ELEMENT

1. Lubricate the sealing surfaces on the filter housing and cover, as well as the O-ring, with clean operating fluid.
2. When fitting a new filter element, check that the designation corresponds to that of the old element.
3. Carefully screw filter element into the cover on the element spigot in a clockwise direction until it is hand-tight.
4. Close oil drain plug.
5. Place cover with element into the housing and turn until the cover is anchored in the screws (bayonet lock).
6. Tighten every other nut on the cover (see tightening torque); the foot valve on the housing opens.
7. Switch on hydraulic system and vent filter at a suitable point in the system.
8. Check the filter for leakage.

#### NOTICE:

Filter elements which cannot be cleaned must be disposed of in accordance with environmental protection regulations!

### 3. SPARE PARTS

#### 3.1 SPARE PARTS DRAWING SPA 100, 150

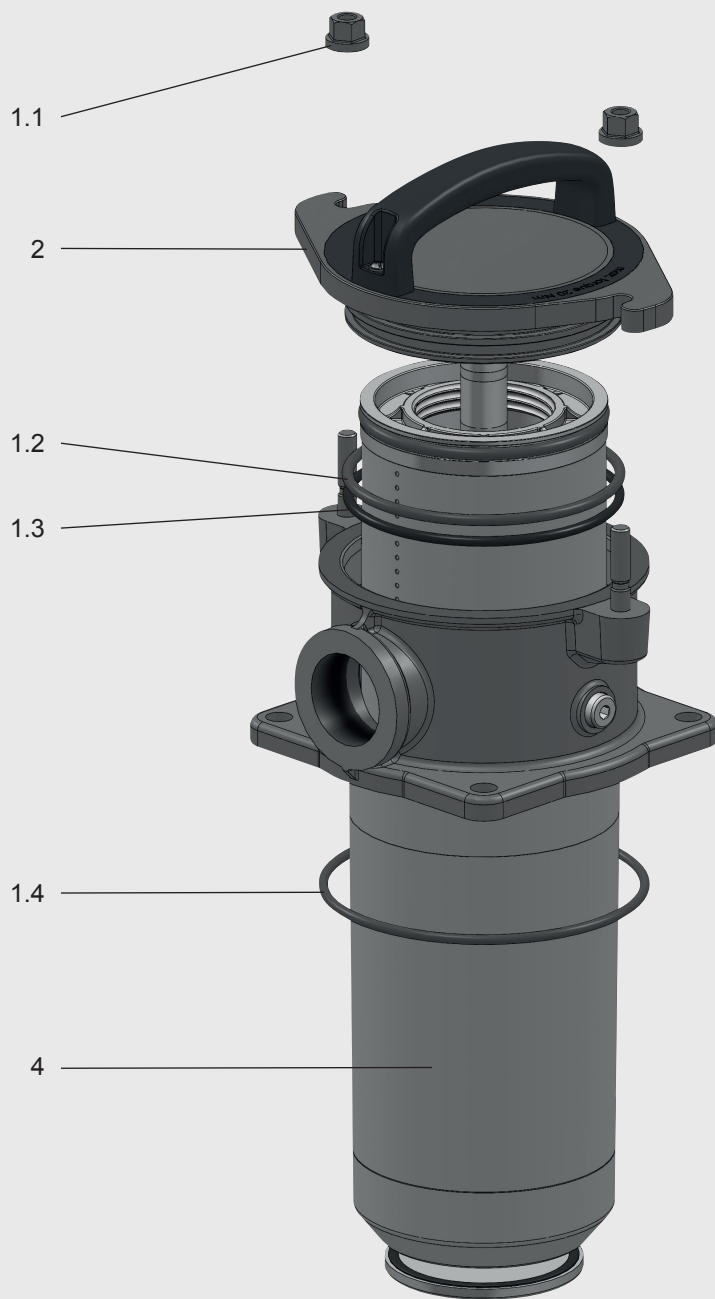

**3.2 SPARE PARTS LIST SPA 100, 150**  
(specified in NBR seals)

Item	SPA 100	SPA 150
1.	SPA seal / nut set (mat. no.: 3591659) 1.1 Hexagon nuts M8-DIN 6331-10-Zn 1.2 O-ring 102x5.0 FKM 1.3 O-ring 102x4.0 FKM 1.4 O-ring 126x4.0 NBR 70	
2.	SPA cover cpl with magnetic core (mat. no.: 200029) 1.2 O-ring 102x5.0 FKM 1.3 O-ring 100x4.0 FKM SPA cover cpl without magnetic core (mat. no.: 200112) 1.2 O-ring 102x5.0 FKM 1.3 O-ring 100x4.0 FKM	
3.	Filter element SOP-0010-100-0110-Q-N-RT WPI-00xx-100-0110-Q-N-RT	Filter element SOP-0010-100-0150-Q-N-RT WPI-00xx-100-0150-Q-N-RT
xx = filtration rating		
4.	SPA 100 filter housing tube cpl with valve (mat. no.: 200030)	SPA 150/180 filter housing tube cpl with valve (mat. no.: 200092)
	SPA 100 filter housing tube cpl without valve (mat. no.: 200113)	SPA 150/180 filter housing tube cpl without valve (mat. no.: 200114)

Special FKM seal design on request!

## 4. MAINTENANCE INSTRUCTIONS

### 4.1 USER INSTRUCTIONS FOR FILTERS



Notice

This pressure equipment must only be put into operation in conjunction with a machine or system.



Notice

The pressure equipment must only be used as stipulated in the operating instructions of the machine or system.



Notice

This pressure equipment must only be operated using hydraulic or lubricating fluid.



Caution

The user must take appropriate action (e.g. air venting) to prevent the formation of air pockets.



Caution

Repair, maintenance work and commissioning must be carried out by specialist personnel only.

Allow the pressure equipment to cool before handling.

The stipulations of the operating instructions of the machine or system must be followed.



Danger

**Caution: pressure equipment!** Before any work is carried out on the pressure equipment, ensure the pressure chamber concerned (filter housing) is depressurised.



Danger

On no account may any modifications (welding, drilling, opening by force, etc.) be carried out on the pressure equipment.



Notice

It is the responsibility of the operator to comply with the water regulations of the country concerned.



Caution

Statutory accident prevention regulations, safety regulations and safety data sheets for fluids must be observed.



Caution

Filter housing must be earthed.



Caution

When working on, or in the vicinity of, hydraulic systems, naked flames, spark generation and smoking are forbidden.



Caution

Hydraulic oils and water-polluting fluids must not be allowed to enter the soil or watercourses or sewer systems.

Please ensure safe and environmentally friendly disposal of hydraulic oils. The relevant regulations in the country concerned with regard to ground water pollution, used oil and waste must be complied with.



Caution

Whenever work is carried out on the filter, be prepared for hot oil to escape which can cause injury or scalding as a result of its high pressure or temperature.



Danger

When using electrical clogging indicators, the electrical power supply to the system must be switched off before removing the clogging indicator connector.



Caution

Filters with switching valve are designed to have a permissible leakage depending on the operating medium. This is independent of the operating medium.

#### Customer Information in respect of Machinery Directive 2006/42/EC

Hydraulic filters are fluid power parts/ components and are therefore excluded from the scope of the Machinery Directive. They will not bear the CE mark! Before using these components, ensure compliance with the specifications provided by RT Filtertechnik GmbH in this documentation.

The specifications also contain information on the relevant essential health and safety requirements (based on Machinery Directive 2006/42/EC) that are to be applied by the user.

We hereby declare that the filters are intended to be incorporated into machinery within the terms of the Machinery Directive 2006/42/EC.

It is prohibited to put the filters into service until the machinery as a whole is in conformity with the provisions of the Machinery Directive.

Furthermore, our Terms of Sale and Delivery are available on our website ([www.rt-filter.de](http://www.rt-filter.de)).

#### SERVICE ADDRESSES

RT-Filtertechnik GmbH  
Buchholz 4  
D-88048 Friedrichshafen  
Postfach 2160  
D-88011 Friedrichshafen  
Tel.: +49 7541 508-0  
Fax: +49 7541 508-101  
E-mail: [sales@rt-filter.de](mailto:sales@rt-filter.de)

## 6.2 MAINTENANCE, GENERAL

This section describes maintenance work which must be carried out periodically. The operational safety and life expectancy of the filter, and whether it is ready for use, depend to a large extent on regular and careful maintenance.

## 6.3 MAINTENANCE MEASURES

- Spare parts must fulfil the technical requirements specified by the manufacturer. This is always ensured when using original RT spare parts.
- Keep tools, working area and equipment clean.
- After disassembling the filter, clean all parts, check for damage or wear and replace parts if necessary.
- When changing a filter element, a high level of cleanliness must be observed!

## 6.4 INTERVAL BETWEEN ELEMENT CHANGES

We generally recommend changing the filter elements at the latest after an operating time of 1 year. When no clogging indicator has been fitted, we recommend changing the elements at specific intervals (the frequency of changing the filter elements depends on the filter design and the conditions under which the filter is operated). When filter elements are subject to high dynamic loading it may prove necessary to change them more frequently. The same applies when the hydraulic system is commissioned or repaired or when the oil is changed. Standard clogging indicators only take effect when the filter is subject to flow. With electrical indicators the signal can also be converted into a continuous display on the control panel. In this case the continuous display must be switched off during a cold start or after changing the element. If the clogging indicator responds during a cold start only, it is possible that the element does not yet need to be changed.

## NOTICE

The information in this brochure relates to the operating conditions and applications described. For applications or operating conditions not described, please contact the relevant technical department. All technical details are subject to change.